

Positioning for circumferential weld seams outside

Loading capacity approx. 4 to

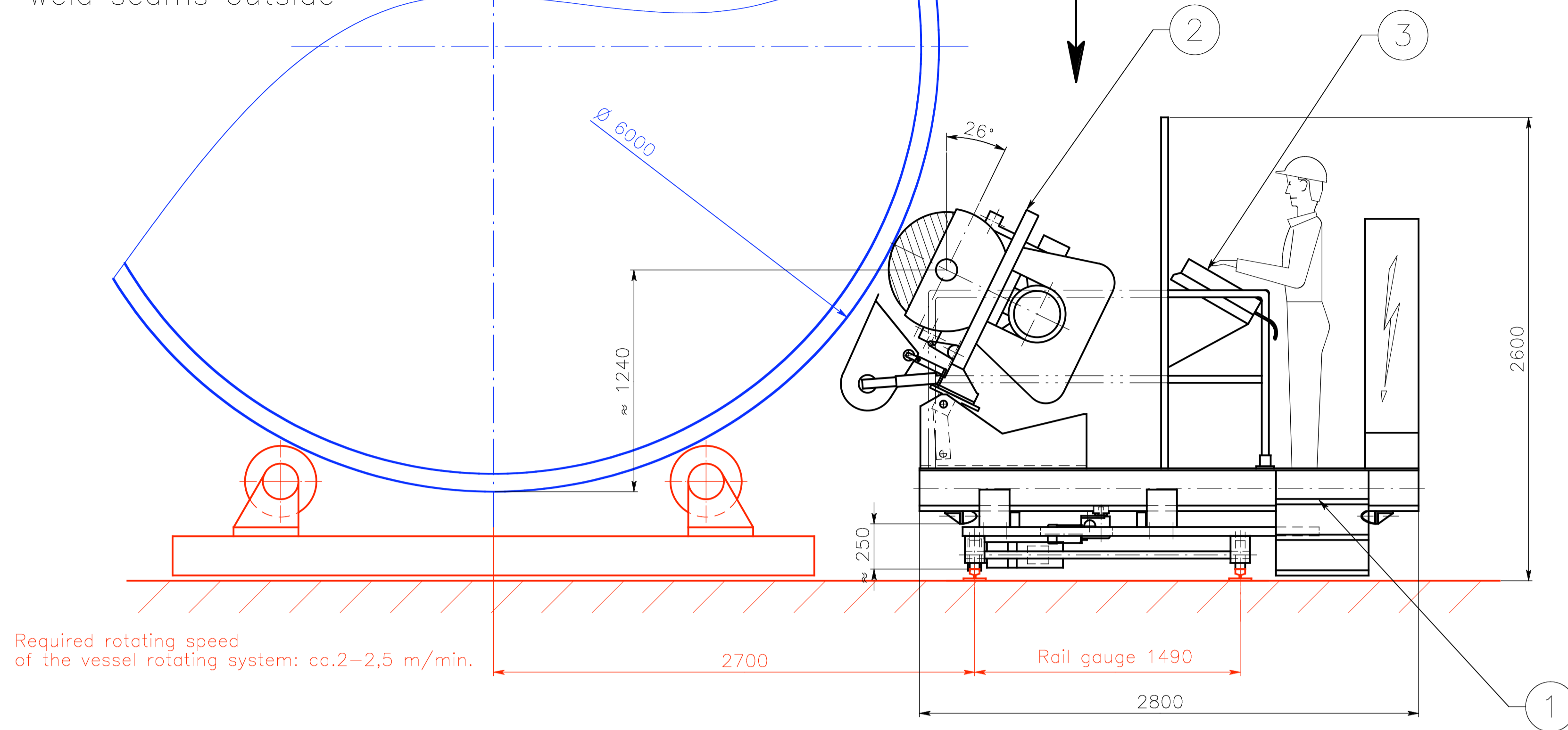

Displacement: 1400

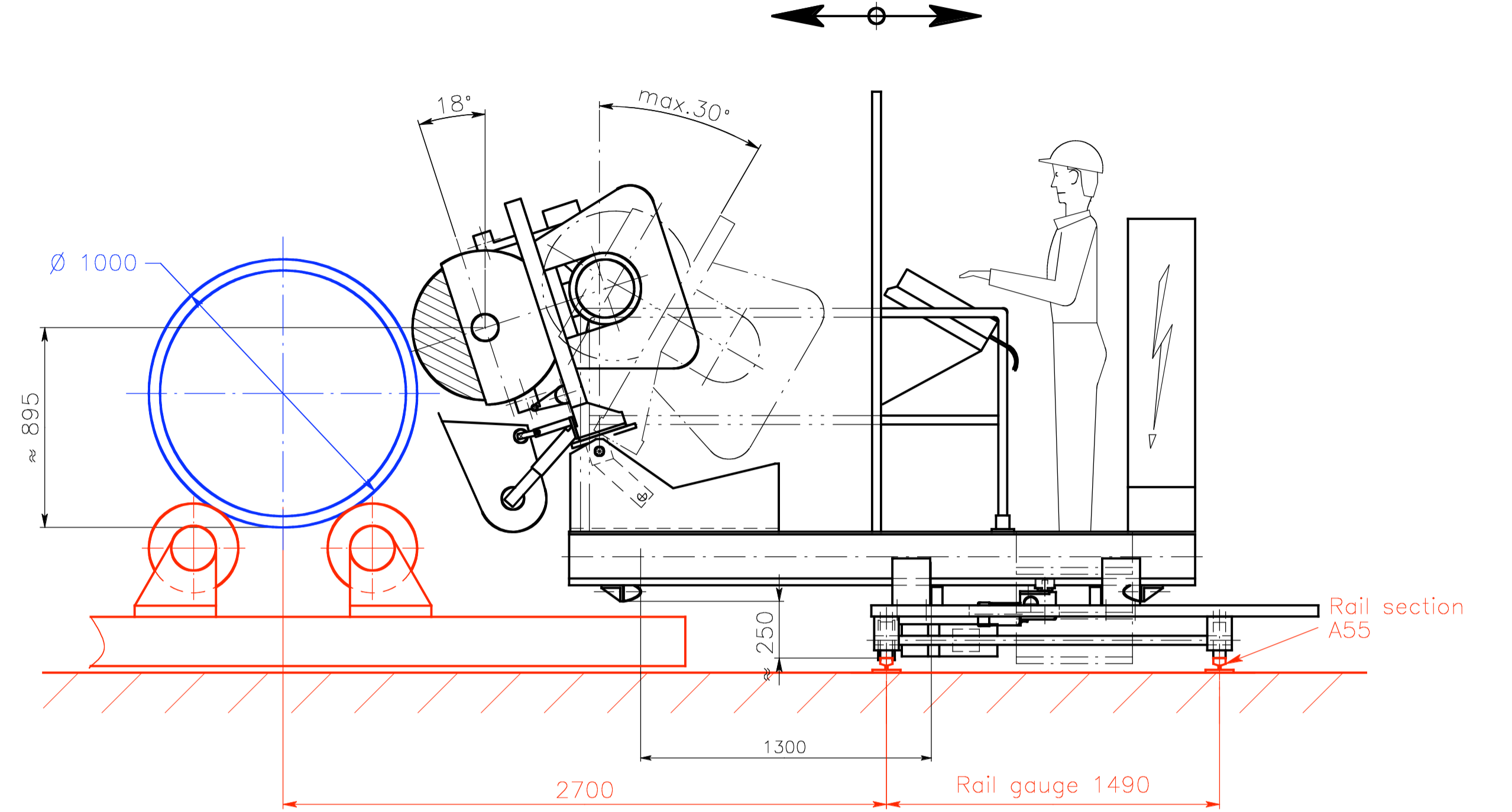

Positioning for longitudinal weld seams outside

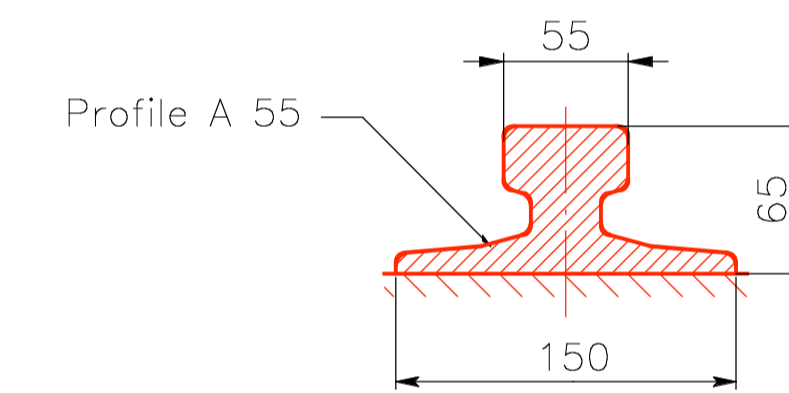
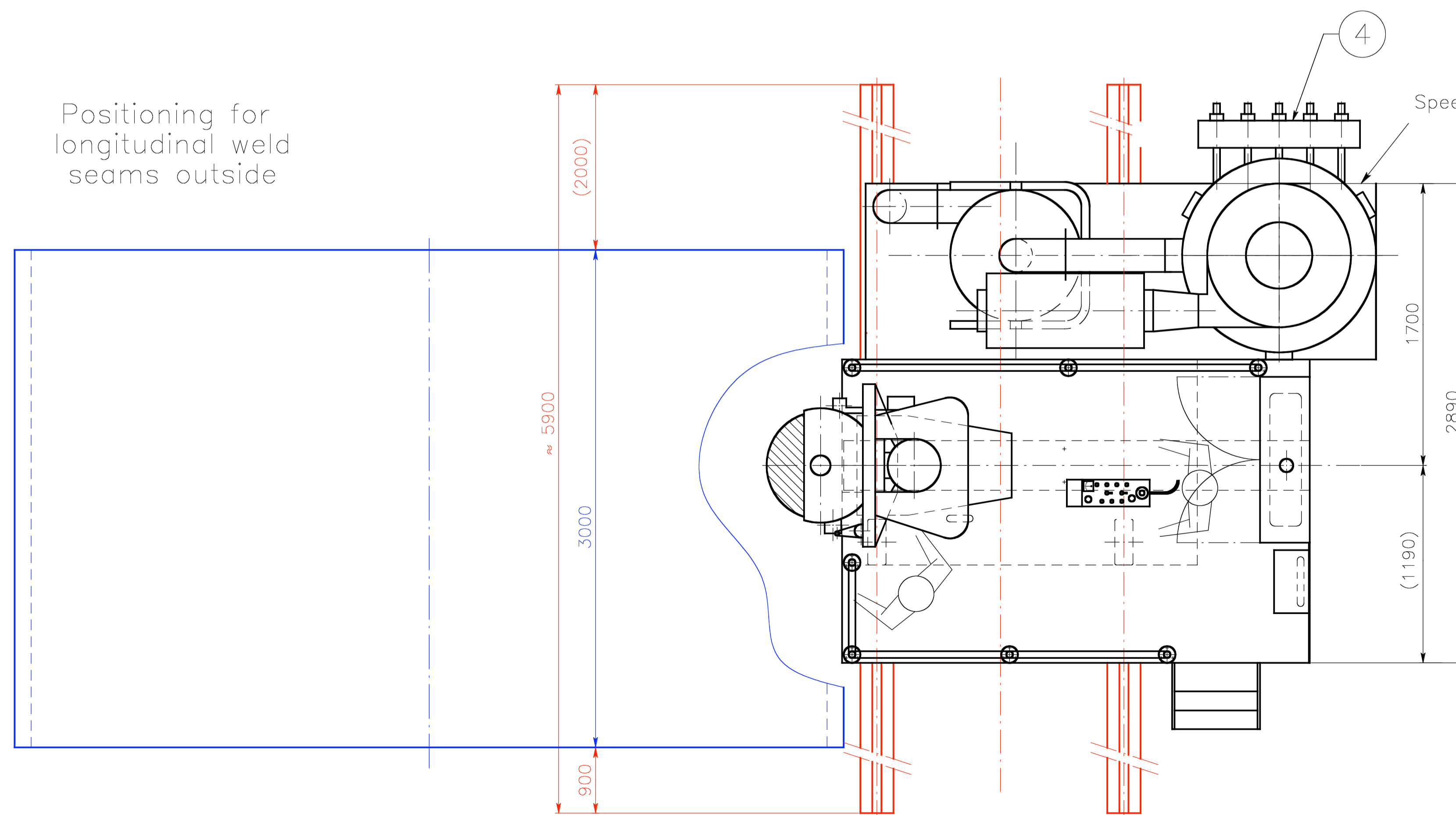

Speed: 0,2...3 m/min.

- Compressed air supply
6bar, 300l/min, Connection G1/2"
- Electric supply 3x415V / 50Hz
18kW / 35A max. 63A

- ① Basic machine type ASA-1400
- ② Grinding head type KS-1200
- ③ Control panel
- ④ Dust extraction

This document is property of
FARROS GRINDING SYSTEMS
and must not be copied or made
available to third parties without
our prior written consent.

All black marked parts
supplied by FARROS GRINDING SYSTEMS

All red marked parts
to be provided by customer

All blue marked parts
components to be machined

Grinding installation for external back gouging of longitudinal and circumferential seams		Maßstab Scale 1:20	Gez. Drawn 21.12.08	KS
		Gepr. Appr.	Datum Date	Visum By
FARROS Grinding Systems		2008069-00-000/1		